

喷砂房 安装说明手册

Sandblasting room Installation instruction manual

版权：本手册版权属于青岛青工机械有限公司所有。没有本公司的书面授权，任何单位或个人不能将本手册复印，翻版，或交给第三者使用。

Copyright: The copyright of this manual belongs to Qingdao Qinggong Machinery Co., Ltd. Without the written authorization of the company, any unit or individual may not copy, reproduce or hand over this manual to a third party.

设备组成

喷砂房体、喷丸罐、斗式提升机、丸砂分离器、螺旋输送机、操作地坪、除尘系统、吊装系统、电控系统以及辅助钢结构等组成。

Equipment composition

Sandblasting room body, shot blasting tank, bucket elevator, sand separator, screw conveyor, operating floor, dust removal system, lifting system, electronic control system and auxiliary steel structure.

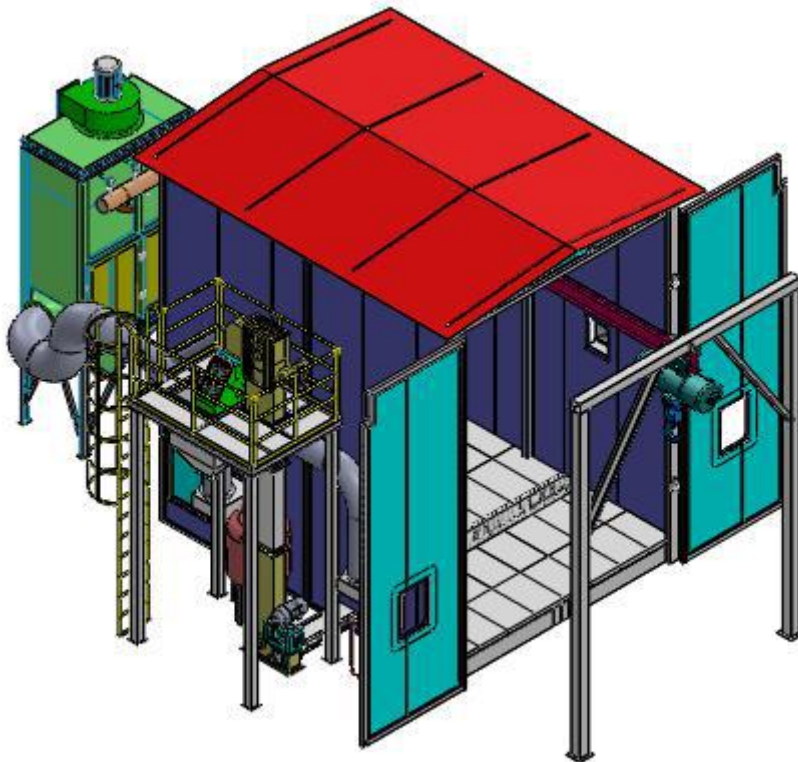

1、喷砂房体

喷砂房体主要由8瓣室体和两扇大门组成，包括必要的附件（8只照明灯和除尘口）和顶部的简易防雨棚

1、 [Sandblasting room](#)

The sandblasting chamber body mainly consists of 8 blocks for enclosure body and two large doors, including the necessary accessories (8 lights and dust removal ports) and a simple rainproof shed at the top.

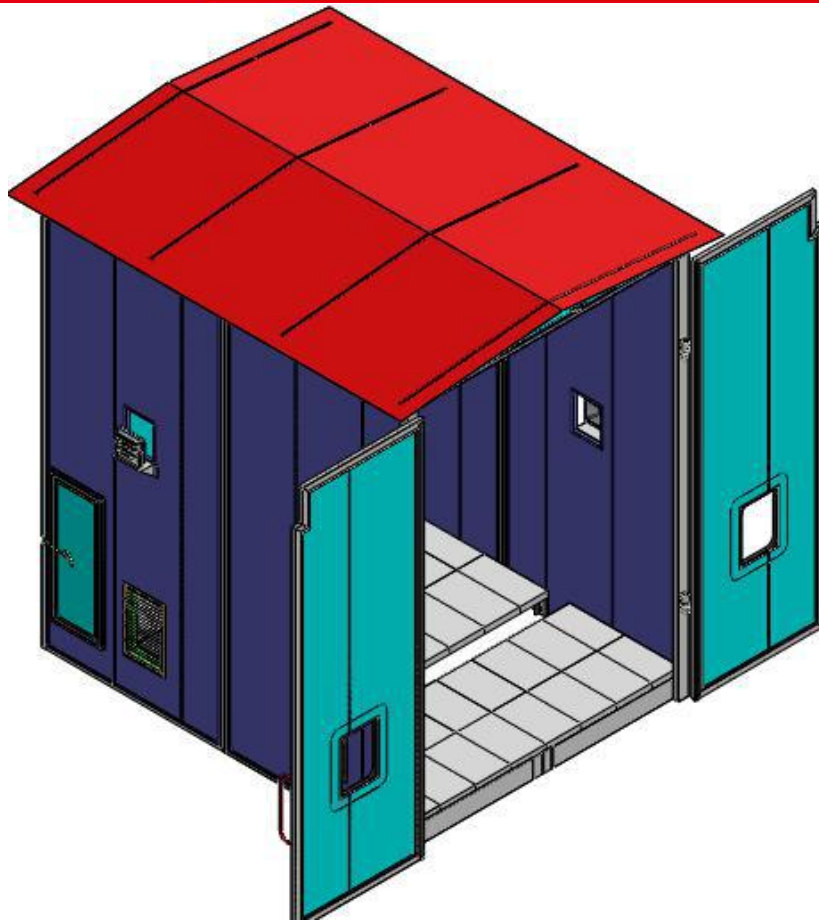

- A 、安装时需要把室体块依次拼装，在相邻的室体中间焊接保证牢固，同时与地面的预埋件焊接，保证不会发生过倾倒。注意：焊接式一定要注意防止室内壁的橡胶板燃烧
- B 、依次把橡胶板悬挂在室内壁，使橡胶板之间相互搭接。
- C 、把8只照明灯固定在室体的四周
- D 、把三角桁架梁依次焊接固定在室体的顶部
- E 、把单层彩板依次用自攻螺丝固定在三角桁架梁上。
- F 、把两个除尘口固定在室体固有的位置上
- G 、把螺旋输送机按照位置穿入固定
- H 、把操作地坪依次摆好固定

A 、 When installing, it is necessary to assemble the chamber body blocks in turn, and the welding in the middle of the adjacent chamber body is ensured to be firm, and at the same time, it is welded with the embedded parts of the ground to ensure that no overturning occurs.

B 、 The rubber sheets are suspended from the inner wall of the chamber in turn so that the rubber sheets overlap each other.

C 、 Fix 8 lights around the chamber

D 、 The triangular truss beam is welded and fixed to the top of the chamber body in turn.

E 、 Fix the single-layer color plate on the triangular truss beam with self-tapping screws.

F 、 Fix the two dust removal ports in the position inherently in the chamber

G 、 The screw conveyor is fixed in position according to the position

H 、 The operating floor is placed in order

2、提升机

提升机主要由提升机上罩、中罩下罩和皮带总成组成

- A 、 安装提升机下罩,使下轴与螺旋输送机相衔接。
- B 、 安装提升机中罩
- C 、 安装维修平台支腿和平台体
- D 、 安装提升机上罩
- E 、 安装皮带总成

2、 Elevator

The elevator are composed of upper cover, middle cover and lower cover and belt assembly

A 、 Install the lower cover of the elevator, and connect the lower shaft of elevator with the screw conveyor.

B 、 Install the middle cover of the elevator.

C 、 Install the maintenance platform legs and platform body.

D 、 Install the hood cover on the elevator.

E 、 installation belt assembly.

3、 分离器 Separator

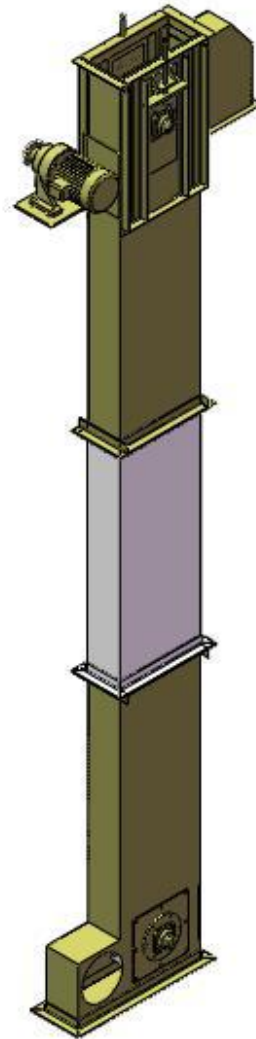

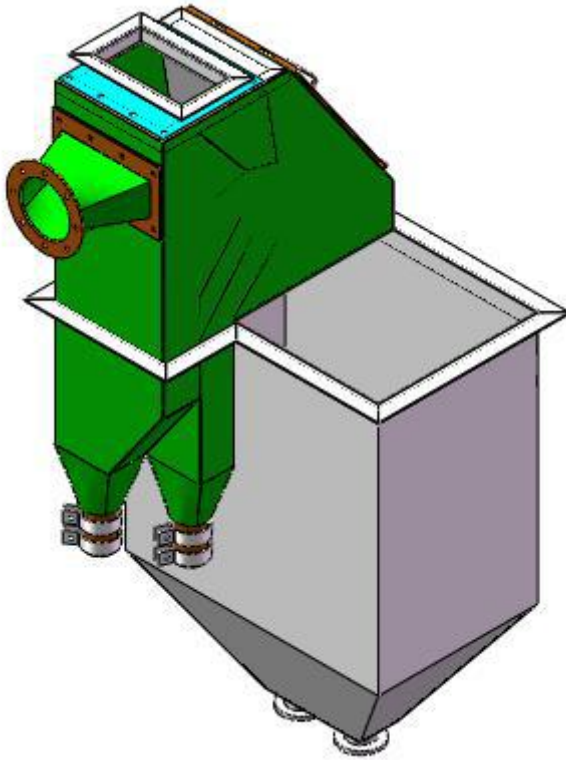

A 、先安装分离器料仓在维修平台上，固定焊接

B 、安装分离器本体与料仓连接，并与提升机上罩相连接

A 、 First install the separator silo on the maintenance platform, fixed by welding

B 、 Install the separator body to connect with the silo and connect with the upper cover of the hoist

4、 喷丸罐

A 、放置喷丸罐在分离器下部

B 、连接分离器下部的流丸管与喷丸罐的进料口上部

C 、连接压缩空气管路与喷砂罐

D 、连接喷枪，并引入喷丸室体

注意、接入的压缩空气要求 无水无油 压力为：0.6-0.8MPa 流量为7m³/min

4、 Shotblasting tank

A 、 Placing the shot blasting tank at bottom of separator

B 、 Connect the abrasive dosing unit under the separator and the feed port of the shot blasting tank

C 、 Connect compressed air line with sand blasting tank

D 、 Connect the blasting gun and introduce it to the blasting room.

Note: that the compressed air require water-free and oil-free. Pressure is: 0.6-0.8MPa Flow rate is 7m³/min

5、 除尘系统

5 、 Dust collector system

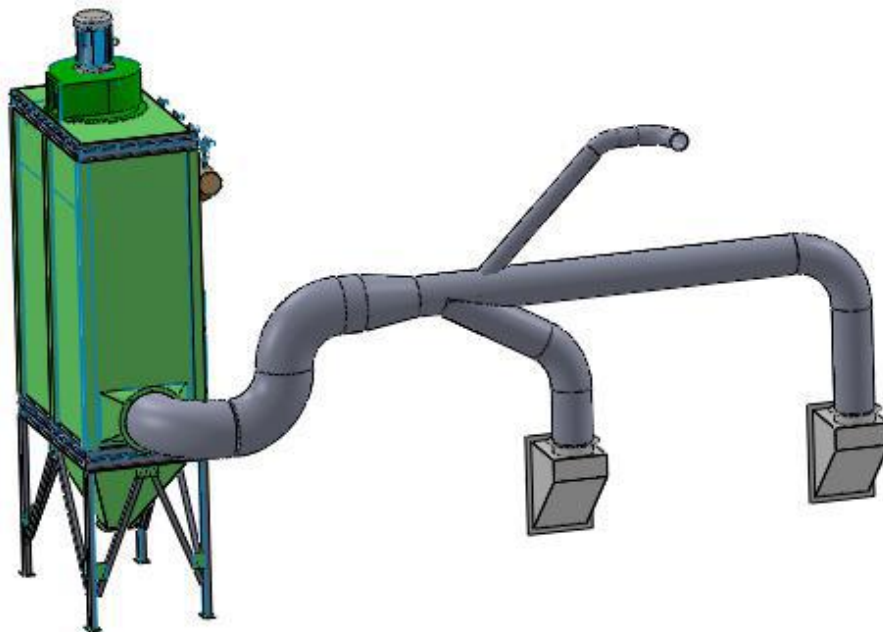

- A 、 组装除尘器 （由料斗和主体组成）
- B 、 依次安装除尘管道 如图

- A 、 Assembling the dust collector (consisting of the hopper and the body)
- B 、 Install dust collecting ducts in turn.

- 6、 吊装系统
- 6、 Overhead lifting system



- A 、 依次固定导轨支架
- B 、 安装5T 电动葫芦

注意： 室体内部的支腿需要与室体的侧壁焊接牢固。

- A 、 Fixed frame in proper sequence
- B 、 Install 5T electric hoist

Note: The legs inside the chamber body need to be welded firmly to the side walls of the chamber body.

7、 电气部分

主要由电控柜和气控部分组成

- A 、 电控柜就位
- B 、 连接各部分的线缆、 详见电器原理图和气控原理图
- C 、 依次调试旋向 如 风机电机的旋向、 提升机的旋转方向 、 螺旋输送器的旋转方向等。

7、 The electrical part

Mainly composed of electric control cabinet and pneumatic control part

- A 、 The electric control cabinet is in place
- B 、 Connect the cables of each part. For details, see the electrical schematic and the air control schematic.
- C 、 Debug the rotation direction for dust collector fan, elevator motor and screw conveyor in sequence.

注意： 为给喷砂房加丸料， 启动螺旋给料机、 和斗提机， 将丸料输送到丸料储存斗， 加入喷砂罐。

Note: In order to add the blasting media to the [blasting room](#), start the screw conveyor and the bucket elevator in sequence, add the blasting media into the screw conveyor system, and then through screw conveyor and lifting by elevator, it will get into the storage bin, via the abrasive dosing unit to get into the blasting tank.

喷砂房 操作手册

Sandblasting Room Operation Manual

版权：本手册版权属于青岛青工机械有限公司所有。没有本公司的书面授权，任何单位或个人不能将本手册复印，翻版，或交给第三者使用。

Copyright: The copyright of this manual belongs to Qingdao QingGong Machinery Co., Ltd. Without the written authorization of the company, any unit or individual may not copy, reproduce or hand over this manual to a third party.

内 容

1	综述
2	安全说明
3	运输
4	主要部件的技术描述
5	保护系统部件
6	喷砂操作前的准备
7	调节和检查
8	操作原理描述
9	怎样操作喷砂房

Content

1	Overview
2	Safety instructions
3	Transportation
4	Technical description of the main components
5	Protection system components
6	Preparation before sand blasting operation
7	Adjustment and inspection
8	Operating principle description
9	How to operate the sandblasting room

1.0 综述

1.0 Overview

1.1 应用和使用设计

1.1 Application and use design

进入喷砂房的工件必须是祛除水渍和油渍的，以防止喷丸过程中引起的钢丸生锈和板结。

喷砂房用于喷钢结构件或清理铝铸件是不同的设计理念，其产生的粉尘有起火和爆炸的危险。因此，此喷砂房不能用于清理铝、镁等合金件。

供应商对用户不遵守上述设计使用所造成的损坏将不承担任何责任，所有的风险将由客户自行承担。

The workpiece entering the blasting room must be removed from water and oil to prevent rust and knotting of the steel shot during shot blasting.

The blasting room is used for shot blasting steel structural parts but not for cleaning aluminum castings. It is a different design principle, and the generated dust from aluminum parts or alloy parts have tendency to caused the risk of fire and explosion. Therefore, this blasting room cannot be used to clean aluminum, magnesium and other alloy parts.

The supplier will not be responsible for any damage caused by the user's failure to comply with the above design, and all risks will be borne by the customer.

一、开机前检查

1. 检查各安全防护罩是否齐全、固定可靠。
2. 检查各控制电源是否连接可靠，接地是否可靠。
3. 检查主气路连接是否牢固可靠，各紧固件是否有松动。
4. 检查手把开关线路及喷砂管等管路是否破损，各接头及喷枪是否有磨损的情况。
5. 检查各软连接部分是否有破损。
6. 检查风机连轴器内油位是否符合要求。如有异常或不符合要求及时处理和更换以防意外。
7. 储气罐、压力表、安全阀要定期检验，砂罐里的过滤滤芯每周检查整理一次，视滤芯损耗程度再进行更换。

1 .check before starting

- ①. Check that each safety guard is complete and reliable.
- ②. Check whether the control power supply is connected reliably and the grounding is reliable.
- ③. Check if the main air line connection is firm and reliable, and whether the fasteners are loose.
- ④. Check whether the pipelines such as the handle switch line and the blast pipe are damaged, and whether the joints and the spray gun are worn.
- ⑤. Check each soft connection for damage.
- ⑥. Check if the oil level in the fan coupling meets the requirements. Handle and replace in case of abnormality or failure to meet the requirements to prevent accidents.
- ⑦. Gas storage tanks, pressure gauges and safety valves should be inspected regularly. The filter cartridges in the sand tanks should be inspected and cleaned once a week, and replaced according to the degree of filter loss.

二、加砂

1. 检查选购的砂料粒度大小是否符合说明书要求。喷砂粒度应与工作要求相符。
2. 加砂时将磨料中的异物清理筛选干净。

2.Feed blasting media

- ①. Check if the size of the purchased blasting media meets the requirements of the manual. The blasting particle size should be consistent with the job requirements.
- ②. Clean and screen the foreign matter in the abrasive before feeding in the blasting system.

三、试喷砂

1. 工作前五分钟须启动空气压缩机及通风除尘设备，空运转五分钟，观察运转是否正常。
2. 压缩空气阀要缓慢打开，气压严禁超过0.8mpa，仔细观察风机的运行是否正常。

3. test blasting system

- ①. The air compressor and ventilation and dust removal equipment must be started five minutes before the work, and the air is running for five minutes to observe whether the operation is normal.
- ②. The compressed air valve should be opened slowly. The air pressure must not exceed 0.8mpa. Observe the normal operation of the fan.

四、喷砂

1. 将工作移进喷砂房，并放平稳，小件须许可靠固定。
2. 穿戴好喷砂工作服，作好喷砂前防护。
3. 手持喷枪（枪口不准对人），枪口对准工件喷砂部位，并启动手把开关开始作业。
4. 喷砂作业时，禁止无关人员靠近，清扫和调整运转部位时，应订机并切断电源进行。

4. sandblasting

- ①. Move the work into the sandblasting room and put it steady. Small pieces must be fixed.
- ②. Wear protection suit.
- ③. Hold the blasting gun (the nozzle is not allowed to aim people), aim the gun at the blasting part of the workpiece, and start the switch to start the operation.
- ④. When sandblasting is performed, it is forbidden for the unrelated personnel to approach. When cleaning and adjusting the operation part, the machine should be ordered and the power supply should be cut off.

五、关机

1. 关闭手把开关，停止喷砂作业。
2. 关闭除尘风机。
3. 除尘风机停机后，保持反吹气源及反吹电源继续反吹请灰约5分钟。
4. 关闭气源及电源。
5. 清洁设备，整理好喷砂工具，及防护装置。
6. 清理粉尘。

5. stop blasting

- ①. Close the handle switch and stop the sandblasting operation.
- ②. Turn off the dust collector fan.
- ③. After the dust removal fan is stopped, keep the jet pulse air source and pulse jet supply continue for about 5 mins.
- ④. Turn off the air supply and power supply.
- ⑤. Clean the equipment, arrange the [sandblasting tools](#), and guard device.
- ⑥. Clean up the dust.

六、其他注意事项

1. 定期清理（工作100小时，湿度交大地区，压缩空气未冷冻干燥许缩短清理周期）除尘器内滤筒上粘附的磨料及粉尘，保障设备正常运转。
2. 开机前须打开气包下部的球阀，将气包的凝结水放干净，以免影响反吹效果。
3. 喷砂作业时必须关闭大门，保持观察窗状态完好。
4. 葫芦进出时应防止撞击大门或人员，并注意防止压住喷砂管 等。
5. 禁止将烟头、棉纱、螺钉等大颗粒或柔软物体留在喷砂房内，以免进入螺旋输送机造成堵塞。
6. 禁止超量投入砂料，禁止将未经过筛的潮湿、渗杂、锈结、粘固的砂料投入砂料系统。
7. 必须按规定穿戴好劳动保护用品。严禁将喷枪对准待喷工件以外的人或其他物件。
8. 每次工作完后，必须将喷砂房内残余磨料全部回收。
9. 喷砂房照明灯具的护网损坏后应及时更换，以免造成灯具的损坏。

6. other matters needing attention

- ①. Regular cleaning (work 100 hours, humidity in areas, compressed air is not freeze-dried to shorten the cleaning cycle) abrasives and dust adhering to the filter cartridge inside the [dust collector for sandblasting room](#) to ensure normal operation of the equipment.
- ②. Before starting the machine, open the ball valve at the lower part of the air bag to clean the condensate of the air bag to avoid affecting the jet pulse effect.

- ③. The door must be closed during sandblasting to keep the observation window intact.
- ④. When the hoist enters and exits, it should be prevented from hitting the gate or personnel, and pay attention to prevent the blasting pipe from being pressed.
- ⑤. It is forbidden to leave large particles or soft objects such as cigarette butts, cotton yarns and screws in the [sand blasting room](#) to avoid blockage caused by entering the screw conveyor.
- ⑥. It is forbidden to over-load blasting media, and it is forbidden to put the wet, infiltrated, rust-free and cemented blasting media that have not been screened into the blasting system.
- ⑦. Labor protection supplies must be worn as required. It is strictly forbidden to point the gun at a person or other object other than the workpiece to be blasted.
- ⑧. After each work, all the residual abrasives in the blasting room must be recovered.
- ⑨. The protection net of the blasting room lighting fixture should be replaced in time to avoid damage to the luminaire.

1. 2 技术参数 喷砂房外形尺寸: 20ft Sand blasting room

No	ITEMS	QTY	PARAMETERS	
1	清理效果		the degree of surface	ISO 8501-1 - Sa 2.5
	Cleaning effect		class of surface	ISO 8501-1 - average
			surface roughness	ISO8501-1:1988 40 μ m~80 μ m
2	丸料规格 Abrasive specification		直径: φ0.8~φ1.5 mm Diameter: φ0.8~φ1.5 mm	
			初始加入量: 1t Initial filling capacity: 1t	
3	喷砂房体 Blasting room body	1 set	尺寸: 20 尺集装箱 Dimension: 20 foot container	
			墙体四周橡胶内衬 Perimetral cover of anti-abrasive rubber	
4	喷砂罐 Abrasive sandblasting machine	1 sets	型号 model	QS0250
			喷枪数量 Gun quantity	1 支 1 pcs (pneumatic remote control)
			文丘里喷嘴直径 Venturi nozzle diameter	Φ10 mm
			工作气压 Working air pressure	5-8 bars
			喷砂罐容积 Volume of in-tank	0.3m ³
			喷射量	1800-2100kg/h

			Emitted dose	
			丸料初始加入量 Abrasive initial filling capacity	1 tons
			空气消耗量 Air consumption	6m ³ /min
5	斗式提升机 Bucket Elevator	1 sets	提升量: 15 吨/小时 Lifting capacity: 15t/h	
			功率: 2.2kW Power: 2.2kW	
			速度: 1.6m/s Speed: 1.6m/s	
6	分离 Abrasive separator	1 sets	Share the same with bucket elevator	
			Separation capacity: 15t/h	
			多级风选分离 Multiple air wash type	
			气流速度: 4-5m/s Air speed: 4-5m/s	
			Storage hopper and abrasive dosing unit (manual+air cylinder control)	
7	收丸螺旋 Screw conveyor	横向螺旋 Crosswise screw conveyor	1 set	长度: 2.8 米 输送量: 15t/h Length: approx 2.8 meters Delivery capacity: 15t/h Gear box motor power: share the same with bucket elevator
8	防尘 LED 灯 Dustproof LED lamp		set	照度: 大约 100lm/w Illumination: more than 100lm/w1 功率: 6×50w Power: 6×50w
9	风量 Ventilation capacity			7000 m ³ /h to 10000 m ³ /h (喷砂房需风量) 7000 m ³ /h to 10000 m ³ /h (required ventilation capacity of the blasting room) 风速: 0.15m/s to 0.25m/s Ventilation speed: 0.15m/s to 0.25m/s
10	除尘		1sets	筒式过滤器: HL6 功率: 7.5kW

	Dust collector <u>(Donaldson filter material)</u> <u>Sequence timer for</u> <u>cleaning of filtering</u> <u>elements)</u>		Cartridge filters:HL6 Power: 7.5kW 风机电机功率： 7.5kW centrifugal fan motor power:7.5kW 除尘效率≥99.2% (自动脉冲反吹) Dust collecting efficiency≥99.2% (automatic pulse jet blowback cartridge filter cleaning) 过滤面积大约是 90 平方米 filtering area about 90 square meters
11	排放标准 Exhaust emissions		<80 mg/ m ³
12	丸料储存料斗 collection silos	1units	Storage capacity: 1t
13	梯子和维护平台 Ladders with maintanance platform	1 Set	梯子和维护平台都有安全防护护栏和检修入口 Platform and ladder with protection, manhole for servicing
14	设备总噪音 entire machine noise		≤85dB
15	电控系统 Electric control system	1 units	Ampere meter, Emergency stop, Manual/automatic key switch, Contactor, button, indicator, Control element 电流表, 急停开关, 手/自动钥匙开关, 接触器, 按钮, 指示灯, 控 制元件
16	总功率 Total power		大约 10kW Approximate:10kW

2.0 安全说明

2.0 safety instructions

此喷砂房是根据标准设计的。然而，由于使用方法不当或用于不同的使用目的或由未经过培训的人员进行操作，都会引起喷砂房内部的损坏。

为获得最大的安全操作，以下提及的人员必须已经仔细阅读和懂得提供的“安全手册”。

- ★ 工厂设备厂长。
 - ★ 喷砂房的主管。
 - ★ 操作、维护和维修人员。
- 我们推荐你确认并记录此条款。

我们强调你的责任 —— 确保《安全手册》、《操作手册》及《维修手册》的完好并：

- ★ 保存在喷砂房的旁边。
- ★ 总是可利用。
- ★ 完整和完好。

因为这些手册是保护系统的一部分。由于不遵守这些手册的操作说明引起的损坏，供应商将不承担任何责任。

喷砂房的操作和服务必须仅由经过培训的操作和维护人员进行；电气系统的工作必须由熟练的电气人员执行。在这方面必须由工厂设备厂长进行明确分工。

This blasting room is designed according to the standard. However, damage to the interior of the blasting room can result from improper use or for different purposes of use or by untrained personnel.

For maximum [sandblasting safety](#), the following mentioned personnel must have carefully read and understood the "Safety Manual" provided.

- ★ Factory equipment manager.
- ★ Supervisor of the blasting room.
- ★ Operation, maintenance and maintenance personnel.

We recommend that you confirm and record this clause.

We emphasize your responsibility ---- to ensure that the Safety Manual, Operation Manual and Maintenance Manual are in good condition.

- ★ Saved next to the sandblasting room.
- ★ Always available.
- ★ Complete and intact.

Because these manuals are part of the protection system. The supplier will not be liable for any damage caused by failure to follow the instructions in these manuals.

The operation and service of the blasting room must be carried out only by trained operations and maintenance personnel; the work of the electrical system must be performed by skilled electricians. In this regard, a clear division of labor must be carried out by the plant equipment manager.

重要

当喷砂房保护系统不完整和不当时，不要操作喷砂房。因此，有必要定期检查保护系统的完整性。

Important

Do not operate the blasting room when the blasting room protection system is incomplete and improper. Therefore, it is necessary to periodically check the integrity of the protection system.

在本手册中没有显示喷砂房的保护装置，仅是做更多说明，这些说明带有示意图。保护系统有任何故障发生，必须立即排除并报告主管或工厂设备厂长。

在对喷砂房进行调节、服务和修理前，你必须根据操作手册的过程说明，将喷砂房进入“零机械状态”。

你可在《维护手册》中找到关于“零机械状态”的准确描述和如何实现它。

完成上述喷砂房的调节、服务或修理后，检查保护系统的所有组件已安装且操作正常。

The protection of the blasting room is not shown in this manual, but for further explanation, these instructions are schematic.

Any failure of the protection system must be immediately removed and reported to the supervisor or plant equipment manager.

Before conditioning, servicing and repairing the blasting room, you must enter the blasting room into a "zero mechanical state" according to the process instructions in the operating manual.

You can find an accurate description of the "zero mechanical state" in the Maintenance Manual and how to implement it.

After completing the adjustment, service or repair of the above blasting room, check that all components of the protection system are installed and operating properly.

警告

未与我们商量，对喷砂房进行修改和结构改变，将会引起安全操作的损坏，这是不允许的。

你要求做任何修改，请与我们联系。

Warning

Failure to discuss with us, modification and structural changes to the blasting room will cause damage to safe operation, which is not allowed.

If you request any changes, please contact us.

注意

当进行切割、打磨或焊接时，总是将灭火器放在手边。

当在喷砂房内进行切割、打磨或焊接时，总是将除尘器保持关闭。

Note

Always keep the fire extinguisher at hand when cutting, sanding or welding.

Always keep the dust collector off when cutting, sanding or welding in the blasting room.

一个清洁的工作环境和遵守安全说明和制度可帮助防止事故的发生并提高喷砂房的使用效率。

确保不仅遵守手册中的安全说明，而且也要遵守当地事故防止条例。

A clean working environment and compliance with safety instructions and systems can help prevent accidents and increase the efficiency of the blasting room.

Be sure to follow not only the safety instructions in the manual, but also the local accident prevention regulations.

3.0 运输

喷砂房到达工厂后如须储存一段时间，必须将其放在干燥，温度变化不大的地方存放。同时必须用帆布将其覆盖。

喷砂房在工厂内运输

为方便喷砂房的运输，所有难于运输的部件都提供有固定吊耳；大的部件的主要尺寸、重量和起吊点见下页图。

控制柜的起吊点和重量是标识在包装箱上。

3.0 Transportation

If the blasting room has to be stored for a period of time after it arrives at the factory, it must be stored in a dry place with little change in temperature. At the same time, it must be covered with canvas.

Sandblasting room transported in the factory

In order to facilitate the transportation of the sandblasting room, all the parts that are difficult to transport are provided with fixed lifting ears; the main dimensions, weight and lifting points of the large parts are shown on the next page.

The lifting point and weight of the control cabinet are marked on the package.

4. 0主要部件的技术描述

4.0 Technical description of the main components

4. 1 喷砂房体

4.1 Blasting room body

喷砂房体由8部分分段的室体壁组成；以及两扇室体大门组成，在室体内部悬挂有耐磨橡胶板地坪由三块组合是模块组成，螺旋输送机安装在中间位置。

The blasting room body is composed of 8 part-segmented chamber body walls; and two chamber body gates, and wear-resistant rubber sheets are hung inside the chamber body
The floor consists of three modules, the screw conveyor is installed in the middle.

4.2 喷丸罐

0.5m³ 间歇式喷丸罐 配10mm喷嘴，详细使用请见 喷丸罐使用说明书

4.2 Shot blasting tank

0.5m³ batch shot blasting tank with 10mm nozzle, please refer to the shot blasting tank instruction manual for detailed use.

4.3 提升机

斗提机将丸料和砂的混合物输送到风选；斗提皮带为带纤发丝加固的橡胶制成；斗子是由低耐磨的可锻铸铁制成；底部皮带轮装有功能监测装置，当皮带松弛或断裂时关闭斗提机。

通过斗提机底部的检修门，你能够更换磨损或掉落的斗子并可检查皮带跑偏情况；也可通过它清理底部堆积的丸料和砂的混合物。

通过斗提机护罩上的检修门可调节或更换偏转板。

4.3 elevator

The bucket elevator lift the blasting media and contaminants mixtures to the separator; the belt is made of rubber with fiber-reinforced; the bucket is made of low wear-resistant malleable cast iron; the bottom pulley is equipped with a function monitoring device, when the belt Close the bucket elevator when slack or break.

Through the access door at the bottom of the bucket elevator, you can replace the worn or dropped bucket and check the belt deviation; it can also be used to clean the mixtures stacked at the bottom.

The deflector can be adjusted or replaced by the access door on the elevator cover.

4.4 螺旋输送机

人工把散落的弹丸均匀加入螺旋槽中，把弹丸和粉尘等输送到提升机中，在端部加装检测装置，可有效检测螺旋输送机是否堵塞。

4.4 Screw conveyor

Manually add the scattered blasting media into the screw conveyor groove, transport the blasting media mixtures into the elevator, and install the detection device at the end to effectively detect whether the screw conveyor is blocked.

4.5 风选分离器

丸料和砂的混合物在风选系统经过均衡器直接进入步梯系统，由于混合物通过步梯系统，逆行的空气流将丸料中的砂分离。

4.5 Air wash separator

The mixture of blasting media and contaminants the step ladder system through the equalizer in the air separation system. As the mixture passes through the step ladder system, the retrograde air stream separates blasting media from the contaminants.

丸料均衡器，阻挡角钢

丸料均衡器是使急速、不均匀的丸料和砂的混合物以均匀的厚度流过步梯。阻挡角钢位于每个步梯的末端，降低丸料和砂的混合物的速度并使其垂直落入下一级步梯。

膨胀箱和闸阀

逆流的空气经过步梯进入膨胀箱；砂、粗粉尘和细小丸料从卸灰管排出，细粉尘是进入除尘器。空气流的速度取决于闸阀的开度。

Blasting media equalizer

The blasting media equalizer let the high speed and uneven blasting media mixture flows through the step ladder system in a uniform thickness. The barrier angle steel is located at the end of each step, reducing the speed of the mixture of blasting medias and sand and causing it to fall vertically into the next step.

Expansion tank and gate valve

The countercurrent air enters the expansion tank through the step ladder; the sand, coarse dust and fine blasting medias are discharged from the discharge pipe, and the fine dust enters the dust collector.

The speed of the air flow depends on the opening of the gate valve.

筛网，储存斗，修理闸阀

位于步梯底部的筛网筛分大量的废料，防止其进入并损坏抛丸器。

经过筛网后，干净的丸料进入丸料储存斗。

在进行维修或修理工作时，通过修理闸阀关闭丸料储存斗到抛丸器的丸料通道。

Screen, storage hopper, repair gate valve

The screen at the bottom of the step ladder screens a large amount of waste to prevent it from entering and damaging the blast machine.

After passing through the screen, the clean pellets enter the pellet storage bin.

When repairing or repairing work, close the abrasive dosing unit to blasting tank.

4. 6 丸料阀

干净的丸料直接从丸料储存斗到给料螺旋进入抛丸器；在到达抛丸器的给料管之前必需经过丸料阀；气动控制的丸料阀作用是停止向抛丸器供丸和提供一定数量的丸料。

4.6 blasting media control valve

The clean blasting media go directly from the blasting media storage bucket to the feed screw into the blast machine; the blasting media valve must pass before reaching the feed tube of the blast machine; the pneumatically controlled blasting media valve stops the blasting media of the blast machine and Provide a certain amount of blasting medias.

5. 0 喷砂房安装前的准备

喷砂房到达客户开始工作前，客户必需做到如下：

按照基础图做的完整的设备基础。

必需的安装主电源和必需确保压缩空气。

如果喷砂房联接中央除尘器，必需提供连接除尘器的风管。

5.0 Preparation of sandblasting room before installation

Before the blasting room reaches the customer to start work, the customer must do the following:

Complete equipment base based on the base map.

Install the main power supply as necessary and ensure that compressed air is required.

If the blasting room is connected to the central dust collector, it is necessary to provide a duct connected to the dust collector.

5. 1 除尘管道的安装

当接支路管时推荐角度为 15° ；在条件限制下可能角度超过 30° ；避免突然改变截面积，主张最大变化角度为 $7^{\circ}\sim 8^{\circ}$ 。闸板阀是安装在除尘器管道的节点处。

5.1 Installation of dust removal ducts

The recommended angle is 15° when connecting the branch duct; the angle may exceed 30° under the condition limit; avoid changing the cross-sectional area suddenly, and the maximum change angle is $7^{\circ}\sim 8^{\circ}$. The gate valve is installed at the node of the precipitator duct.

注意：

对于喷砂房不允许清理铝铸件，所有管路连接必需为电力连接并接地，其它情况请参照事故防止制度。

note:

For the blasting room, it is not allowed to clean the aluminum castings. All the pipeline connections must be connected and grounded. For other cases, please refer to the accident prevention system.

5. 2 丸料

丸料是影响清理效果和喷砂房效益的主要因素，我们推荐使用高强度铸钢丸料或切丸。我们坚决反对使用铁丸。其差的耐久性和尖锐的边及特殊的材质将导致抛丸器和衬板过早磨损。

丸料的配比

大多数情况下，丸料由不同尺寸的圆丸粒混合而成；中间尺寸的丸粒占主要部份，粗的和细的丸粒也是很有用的部份。

粗的丸料去掉表面层，中间尺寸丸料执行主要的清理工作，细的丸料清理并光亮细化表面。

5.2 Blasting media

Blasting media are the main factor affecting the cleaning effect and the efficiency of the blasting room. We recommend the use of high-strength cast steel shot. We are firmly opposed to the use of iron Blasting media. Its poor durability and sharp edges and special materials will cause premature wear of the blast machine and liner.

Ratio of blasting media

In most cases, the blasting media are made up of round shot of different sizes; the intermediate size shot are the main part, and the coarse and fine blasting medias are also useful parts.

The coarse shot remove the surface layer, the intermediate size shot perform the main cleaning work, and the fine shot clean and brighten the surface.

6. 0 调节和检查

喷砂房完成安装后由我们的人员启动喷砂房；在安装和服务期间，我们的人将对维护及操作人员进行培训。

手册这一章“调节和检查”介绍给维护及操作人员，它也是在维护或维修后帮助你重新启动喷砂房。

6.0 adjustment and inspection

After the installation of the blasting room, our personnel will start the blasting room; during the installation and service, our people will train the maintenance and operation personnel. This chapter of the manual "Adjustment and Inspection" is introduced to maintenance and operation personnel. It also helps you restart the blasting room after maintenance or repair.

6. 1 齿轮电机的准备工作

检查每个齿轮箱的润滑油填充情况。
关于润滑油的型号和加油量，请参照制造商的耐磨件和易损件说明书文件。
检查齿轮箱的呼吸塞是否旋好。

6.1 Preparation of gear motor

Check the lubrication of each gearbox.
Check that the breather plug of the gearbox is properly rotated.

6. 2

重要

如果电机转向不对，泵可能短时间操作将会损坏。

Important

If the motor does not rotate in the right direction, the pump may be damaged in a short time.

6. 3 电气系统检查

电气系统的检查必须在手动操作方式下执行。

单独检查每个急停按钮

给控制系统送电，选择手动操作方式并激活一个急停按钮；“故障/故障确认”按钮灯必须亮，同时控制系统必须关闭。在你继续检查急停按钮前必须按下“故障/故障确认”按钮。

检查电机的旋转方向

如果转向错误，调换电机的接线；必须是在控制柜的接线端子上调换。

6.3 Electrical system inspection

Inspection of the electrical system must be performed in manual mode.

Check each emergency stop button separately

Power the control system, select the manual mode and activate an emergency stop button; the "Fault / Fault Confirmation" button light must be on and the control system must be turned off. You must press the "Fault/Fault Confirmation" button before you continue to check the emergency stop button.

Check the direction of rotation of the motor

If the rotation direction is wrong, replace the wiring of the motor; it must be exchanged on the terminal block of the control cabinet.

6. 4 喷砂房装丸料

为给喷砂房加丸料，启动螺旋给料机、和斗提机，将丸料输送到丸料储存斗，加入喷砂罐。

6.4 Blasting media feeding for Sandblasting room

In order to add the blasting media to the blasting room, the screw conveyor and the bucket elevator are started, the blasting media are transported to the blasting media storage hopper, and then through the abrasive dosing unit into the blasting tank.

7 喷砂房操作说明

7.1 启动喷丸清理系统前的检查

在启动喷砂房以前必须进行以下检查工作：

气动系统：

- 检查油雾器的油位。
- 检查/排空气水分离器内的水。
- 打开主气路的截止阀并检查压力表的读数；压力表的操作压力最小为 6 巴。

风选：

- 检查风选下部的筛网，如果必要清除废料。

抛丸清理系统：

- 确认所有的检修门和护栏已关闭，且没有人员在工作区内。
- 确认所有的盖板和安全标示已安装且完好。

7 Sandblasting room operation instructions

7.1 Inspection before starting the shotblasting system

The following inspections must be carried out before starting the blasting room:

Pneumatic system:

- Check the oil level of lubricators.
- Check/discharge the water mixture in the air&oil separator.
- Open the shut-off valve of the main air line and check the reading of the pressure gauge; the operating pressure of the pressure gauge is at least 6 bar.

Air wash separator:

- Check the screen in the lower part of the air wash separator and remove the waste if necessary.

Blasting system:

- Verify that all access doors and guardrails are closed and that no personnel are in the work area.
- Verify that all covers and safety signs are installed and in good condition.

7.2 操作方式

7.2.1 手动方式

手动方式是单个操作设备。先启动提升机、后启动螺旋输送机。通过电动葫芦把需要喷丸的工件吊入工作区域。人员需要穿好所有护具，才能进入喷丸室。

7.2 Mode of operation

7.2.1 Manual mode

The manual mode is a single operating device. Start the elevator first, then start the screw conveyor. The workpiece that needs to be shot is lifted into the work area by the electric hoist. Personnel need to wear all the protective suit and respiration helmet in order to enter the shot blasting room.

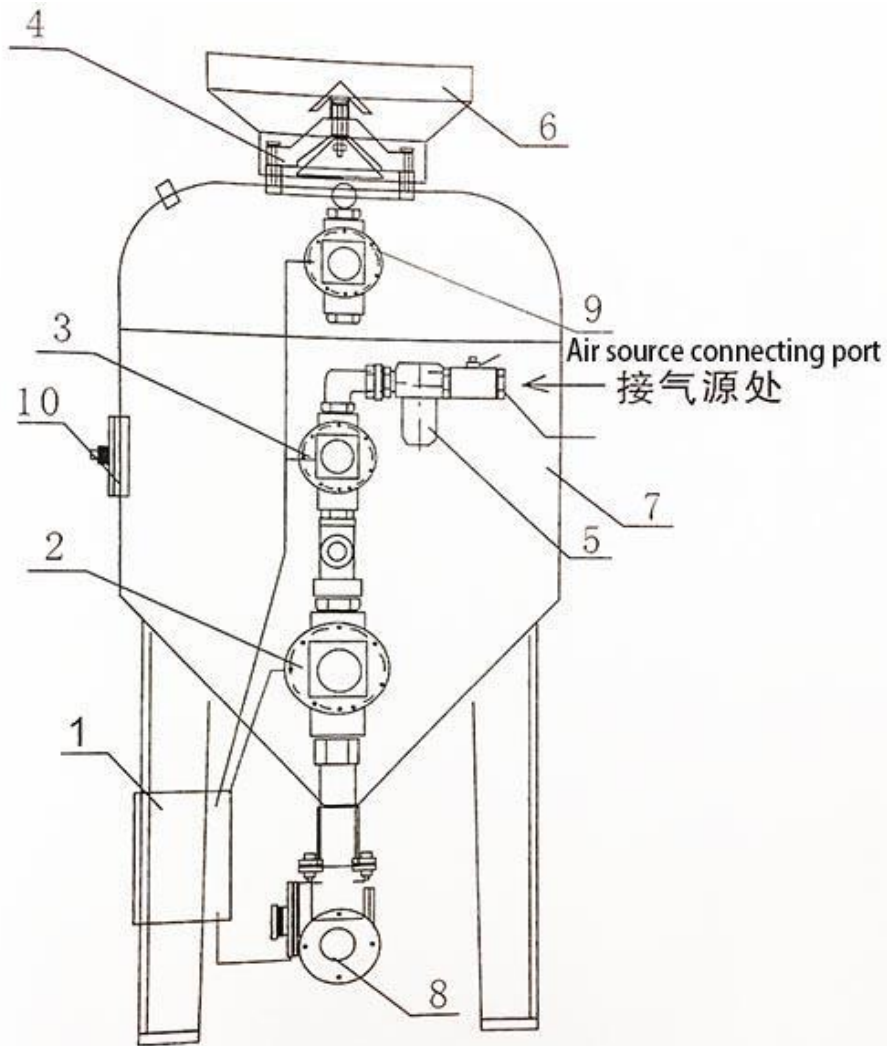

- 1. Solenoid valve cabinet
- 2. air jet valve
- 3. air charge valve
- 4. blasting media feeding valve
- 5. oil-water separator
- 6. hopper
- 7. blasting pot
- 8. abrasive control valve
- 9. air discharge valve
- 10. Maintenance window

Q0250A Single Blasting Gun Blasting pot circuit diagram

