

Airblasting Booth

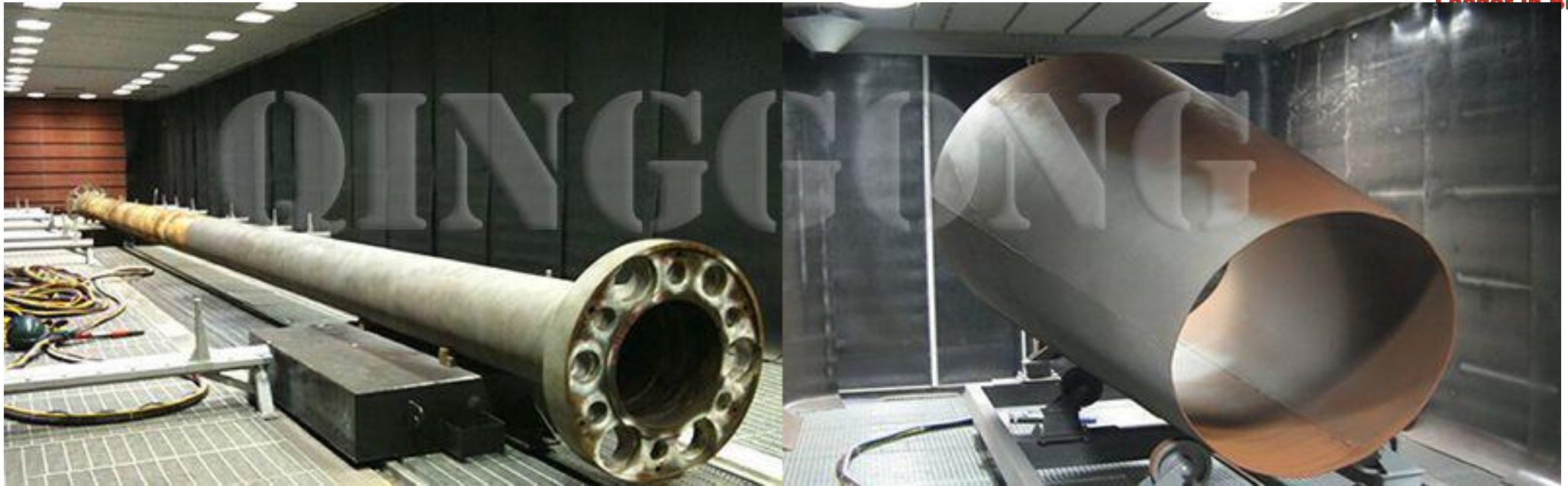



QINGGONG provides industry with high quality, dependable blast room equipment

Blast room equipment is used in a wide variety of industries that require surface preparation prior to the application of a protective coating. The surface of the work piece is cleaned by a mixture of abrasive and high pressure compressed air being directed at the work piece by a blast operator. The operator holds a venturi nozzle tipped hose in his hands and controls the abrasive/air mixture generated at the blast machine with an "on the hose" operator switch.

The blast room contains the abrasive being shot at the work piece as well as providing lighting and ventilation for the operator's safety. The

QINGDAO QINGGONG MACHINERY CO.,LTD



Leader in Blasting

abrasive and surface particle mix (i.e. paint chips, surface rust, mill scale, etc.) are collected by the floor reclamation system and brought back to the classifier to separate reusable abrasive from waste. The reusable abrasive is stored in a bin above the blast machine and is ready for the cycle to start again.



Industries that require this process include

• **Steel Fabricators**

• **Construction Equipment**

NO.807, 6 HAIBIN ROAD 266400 QINGDAO CHINA

T:+86 532 82121566

F:+86 532 82121527

M:+86 13235322903

E:info@shotblastpro.com

www.shotblastpro.com

- Railcars*
- Steel Tanks*
- Trailers*
- Oil Field Equipment*
- Ship Building*

QINGGONG offers a variety of reclaim floor designs and room configurations which allow us to design a blast room facility uniquely tailored to meet the economic production, safety and environmental concerns of each customer.

Environmentally Safe

Environmentally Safe

Air-blasting eliminates many of the environmental problems and costs associated with chemical stripping because you don't have to manage or dispose of hazardous liquids.

An QINGGONG blast room provides even greater potential for improving safety and reducing operating costs when you're cleaning, finishing or surface-profiling large work pieces. With the process contained in a specially designed enclosure, blast media and debris are isolated from the external environment. And the operator, equipped with QINGGONG safety gear, is fully protected.

Recovery Floor: From simple to sophisticated

Qingong offers recovery floors to meet almost any budget and production requirements. The sweep-chute floor shown below, for instance, delivers the economic and environmental benefits of media recycling at a modest cost.

In higher volume applications where both production speed and labor cost become important considerations, you can select the Sweeper Blade Full Floor Reclaim System.

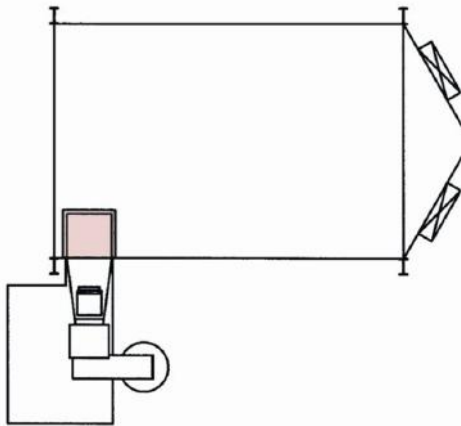

sweep-chute floor

The sweep-chute floor, delivers the economic and environmental benefits of media recycling at a modest cost.

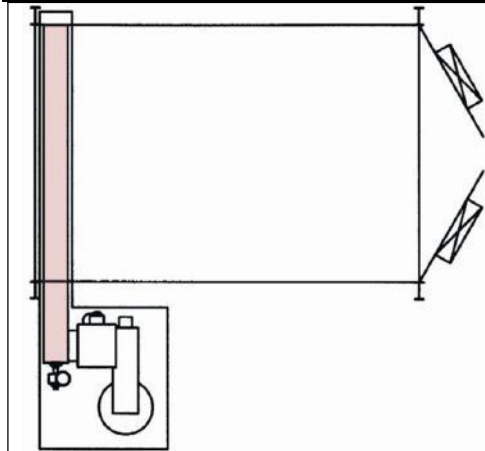

Single Screw Partial Reclaim System

The most economical floor design available. The system contains metering shed plate, heavy duty screw belt and bucket elevator. 20" air-wash separator, perforated plate rotary drum separator and oversized abrasive storage hopper with a caged man ladder and handrail. This can be expanded to an "H", "U", or full floor reclaim system and is best suited for low to medium production levels.

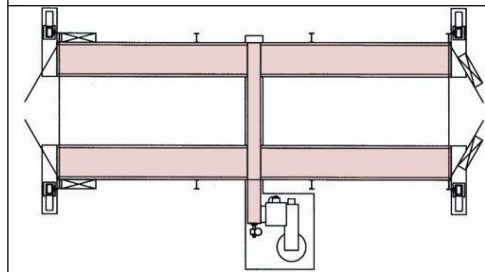

"H"-Shaped Partial Reclaim System

Adds two longitudinal metered screw assemblies along each side wall of the blast room allowing the abrasive delivered from the blasting nozzle, which is either blown or rebounded off the work piece, to strike the side walls and fall into the screws, automatically reclaiming approximately 60-90 percent of the blast media. The reclaiming abrasive on the floor is pushed into the metered shed plate screw assemblies at the end of the work shift. The "H" shape floor design is typically used in a "flow-through" room configuration where heavy work pieces and/or material handling devices can drive into the room. This is best suited for medium to high production.

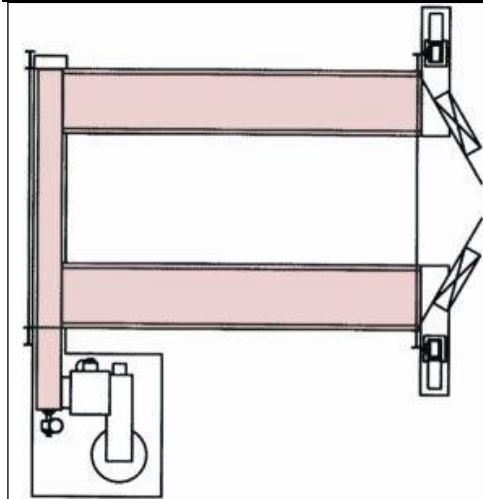

“U”-Shape Partial Reclaim System

Adds two longitudinal metered screw assemblies along each wall of the blast room and positions the cross screw along the back wall of the blast room. This allows the abrasive delivered from blasting nozzle, which is either blown or rebounded off the work piece, to strike the side walls and back wall of the blast room and fall into the reclaim system. A “U”-shape floor design will automatically reclaim 60-90 percent of the blast media. The remaining abrasive on the floor is pushed into the metered shed plate screw assemblies at the end of the work shift. The “U”-shaped floor design is typically used in an “in-out” room configuration where heavy work pieces and/or material handling devices can drive into the room. This is best suited for medium to high production.

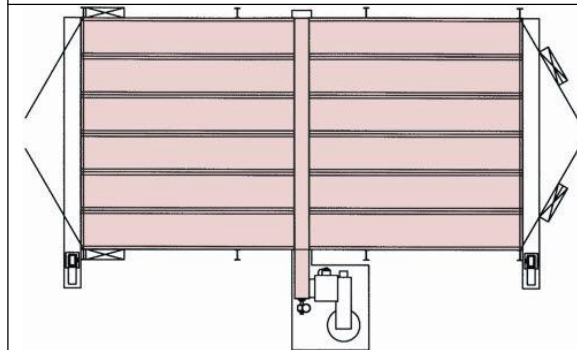

Unique Sweeper Blade Full Floor Reclaim System

A major benefit of this type of system is that it only requires a shallow concrete foundation. This can create substantial savings for the customer in comparison to other types of recovery systems. It also avoids the issue created by digging foundations in areas that have high water table levels. The full floor reclaim design requires that the material handling of the work piece be intricately designed into the configuration of the room. Material handling of the work piece includes a work car/track system, an overhead monorail crane, an overhead bridge crane or guide rail work cars, heavy-duty floor

QINGDAO QINGGONG MACHINERY CO.,LTD



grating and support steel sized to allow a forklift to drive onto the reclaim floor. This design can be used with any room configuration and is best

